

MAXTON UC-1A Valve Adjustment

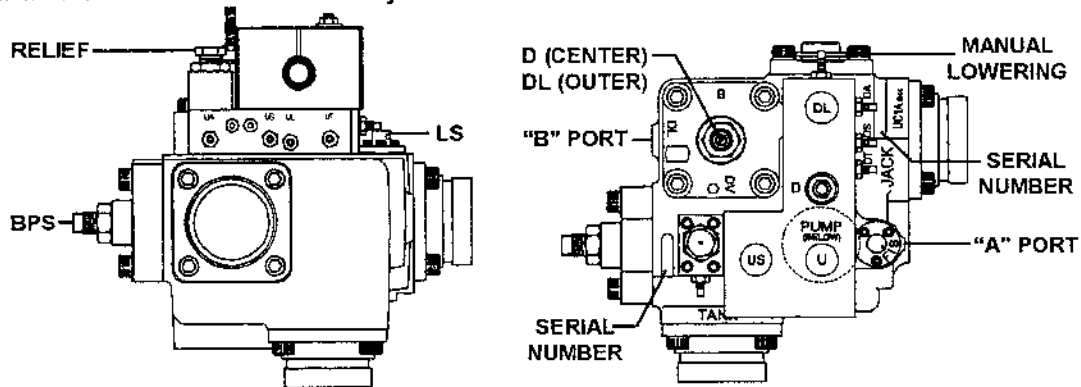

- Make all adjustments at minimum pressure (no load on elevator) except where noted.
- "IN" is ALWAYS (CW) clockwise. "OUT" is ALWAYS (CCW) counterclockwise.
- The control plate adjusters have seal nuts, not lock nuts. Adjust nut only to set seal friction (friction will maintain during adjustment).
- When adjustment procedure calls for coils to be disconnected, disconnect them electrically. Do Not Remove them physically.
- Make adjustments with a minimum oil temperature of 80 degrees F, not to exceed 100 degrees maximum.

MAXTON UC-1A Valve Adjustment (cont'd)

UP SECTION ADJUSTMENTS

Initial Settings:

US	UP STOP	OUT (CCW) to stop (faster rate)
UL	UP LEVEL	IN (CW) to stop (slower speed)
UA	UP ACCELERATION	IN (CW) to stop (slower rate)
UT	UP TRANSITION	OUT (CCW) to stop (faster rate)
BPS	BY-PASS SIZING	OUT (CCW) to stop (delays up start)
LS	LEVEL SPEED (factory set)	DOT ON LINE
R	RELIEF (factory set at 450 psi)	

Adjusting Procedure:

1	BPS	Disconnect the US coil (ULVS). Run the car up and turn BPS IN (CW) until the car just moves. Next, turn BPS OUT (CCW) until the car just stalls then turn it OUT another 1/2 turn. Tighten locknut on BPS and stop the pump. Reconnect ULVS.
2	UA	Attempt to run the car up (pump running and US and U coils energized, car should not move). Slowly turn UA OUT (CCW) to attain full up speed within 24 to 36 inches. Lower car to bottom floor.
3	UL	Disconnect the U coil (UMVS) and run car up. Leveling speed should be 3 to 5 fpm with UL fully IN (CW) (if not, re-adjust LS). Turn UL OUT (CCW) to attain 9 to 12 fpm leveling speed. Reconnect the U (UMVS) COIL and lower car to bottom floor.
4	UT	Run car up and turn UT in (CW) so that the car slows to provide 4 to 6 inches of stabilized up leveling. Repeat 3 and 4 as necessary.
5	US	Disconnect both the U and the US coils. Place a call and slowly turn the US adjustor in (CW) while watching the pressure gauge. When a slight pressure increase is seen stop turning the US adjustor (the sound of the oil movement will change at this time). Turn US adjustor out (CCW) 1/2 turn. This setting will insure that the elevator will not move without valve activation and should not be used to adjust floor stops. Further adjustment of floor level should be achieved using the MCSS parameter, "Up level off Delay". (Note: Once this adjustment is complete the operation MUST be checked to insure that the elevator does not move when the pump runs without up solenoid activation (see instructions on sheet 3).
6	LS	Dot on adjustor should be referenced to line between F and S. When necessary, move LS adjustor slightly toward S for slow or F for faster leveling speed. Adjustment should be made only when UL adjustor is IN (CW) to stop. Set coarse adjustment from 3 to 5 fpm during leveling.

MAXTON UC-1A Valve Adjustment (cont'd)

DOWN SECTION ADJUSTMENTS

Initial Settings:

DS	DOWN STOP	OUT (CCW) to stop (faster rate)
DL	DOWN LEVEL	OUT (CCW) 2 threads above lock nut (faster speed)
DA	DOWN ACCELERATION	OUT (CCW) to stop (faster rate)
DT	DOWN TRANSITION	OUT (CCW) to stop (faster rate)
D	DOWN SPEED	OUT (CCW) 4 threads above lock nut (faster speed)

Adjusting Procedure:

1	D	Run car down to set proper down speed (20% less than contract speed) with down speed adjustment D as required. Send car to upper floor. Note: This adjustment MUST be checked with full load to insure that the down speed does not exceed contract speed
2	DA	Start by turning DA adjustor IN (CW) to stop. Attempt to run the car down and turn the DA adjustor slowly OUT (CCW) until the car accelerates smoothly (attain full speed within 2 inches for every 10 fpm of car speed)(100fpm=20", 125fpm=25", 150fpm=30"). Send car to upper floor.
3	DT	Disconnect DL (DLVS) coil. Run car down and turn DT IN (CW) until car slows to stop 6 to 9 inches from floor level. Send car to upper floor. Reconnect DL (DLVS) coil.
4	DL	Disconnect D coil (DMVS). Run car down, hold the D adjustor in place and set down level speed at 6 to 9 fpm with the DL adjustor. Tighten the locknut (snug) on DL. Reconnect DMVS coil.
5	DS	Turn DS in (CW) for a softer stop.

Quick Summary:

BPS	Sets up stall position of Bypass plunger inside valve. CW makes car move. CCW stalls car.
UA	CCW makes car start up faster. CW makes car start up slower.
UL	CCW increases Up Leveling Speed. CW decreases Up Leveling Speed.
UT	CCW makes car slow down faster in up direction. CW makes up transition smoother but makes car take longer to slow down and can cause overshooting.
US	CCW makes car stop harder in up direction at floor level, CW makes car stop smoother but if turned CW too much can cause overshoot.
LS	Coarse up level speed adjustment (see instructions)
DA	CCW makes car start down faster. CW makes car start down slower.
D	CCW increases Down full speed. CW decreases Down full speed.
DT	CCW makes car slow down faster in down direction. CW makes down transition smoother but makes car take longer to slow down and can cause overshoot.
DL	CCW increases down level speed. CW decreases down level speed.
DS	CCW makes car stop harder in down direction at floor level. CW makes car stop smoother but if turned CW too much can cause overshoot.

MAXTON UC-1A Valve Adjustment (cont'd)

Relief Valve Adjustment:

- a. Land the elevator in the pit and install a pressure gauge in the to/from line port.
- b. Register an up call with a fully loaded elevator, making note of the maximum operating pressure.
- c. Turn UA and the Relief Adjustor OUT (CCW) seven turns.
- d. Register an up call and slowly close the ball valve in the machine room as the pump starts running. This method will prevent trapping a pressure spike, which could occur if the up run started with the ball valve closed.
- e. Observe the pressure gauge and turn the Relief Adjustor IN (CW) to increase pressure. Final setting should be in accordance with local code requirements not to exceed 150% of maximum operating pressure.
- f. Tighten the locking nut (snug tight).
- g. Restart to check the pressure relief setting. Seal as required.
- h. Open the ball valve and readjust UA for proper acceleration.

Note: The final testing of the relief valve should be done with the elevator on the stop ring. This will test the complete system under rated conditions.