

# Viking

# TECHNICAL Practice

TELECOM SOLUTIONS FOR THE 21ST CENTURY

**1600A Series**

ADA Compliant  
Emergency Phones

January 7, 2000

## ADA\* Compliant Emergency Phone with Built-In Digital Voice Announcer

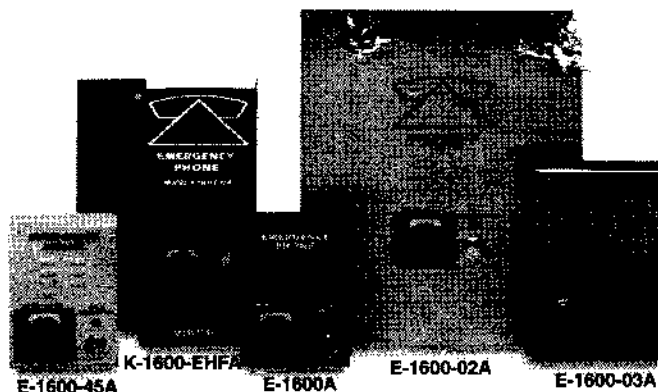

The 1600A series emergency phones are designed to provide quick and reliable handsfree communication over the public switched telephone network. The 1600A series meets ADA\* requirements for elevator telephones, and can be programmed from any Touch Tone phone. The 1600A series phones can automatically send the digital announcement to identify the location of the emergency call, then automatically light the call connected LED.

The 1600A series can also be used with Central Station Monitoring equipment. All parameters, phone numbers and location numbers are stored in non-volatile E<sup>2</sup> memory. All units are phone line powered, requiring no batteries or external power sources.

### Features

- Non-volatile digital voice announcer with 10 seconds of voice memory
- Advanced call progress detection
- Can automatically light the "Call Connected" LED for the hearing impaired
- Handsfree operation
- Phone line powered
- Non-volatile E<sup>2</sup> memory (no batteries required)
- Touch Tone or pulse dialing
- Dials up to 5 different numbers on busy or no answer
- Transmits a unique location I.D. code
- Grade 2 Braille label for the visually impaired
- Hangs up on CPC, silence, busy signal, dial tone, time out or Touch Tone command
- Programmable to auto-answer on incoming calls
- Remotely programmable
- Extended temperature range (-15°F to 130°F)
- 5 different chassis or board only available
- Central Station Monitoring capability
- Separate central station voice speed dial number
- Optional PB-100 Polling System available

### Applications

- Elevators
- Parking ramps
- ATM machines
- Area of refuge locations
- Lobbies
- Entryways
- Campus emergency stations
- Roadside emergency stations
- Stadiums
- Convention centers

\* Americans with Disabilities Act of 1992 contains federal regulations regarding elevator telephones (Public Law 101-336).

Phone...715.386.8861

info@vikingelectronics.com

http://www.vikingelectronics.com

# Installation and Specifications

Viking offers five different chassis for the 1600A series emergency phones. In addition, the circuitry, button, speaker, etc. are available for custom applications. The following sections show mounting dimensions and chassis specifications. All PCB's are conformal coated for added weather resistance.

## E-1600A and E-1600-45A

**Power:** Phone line powered (24VDC talk battery w/20mA loop current minimum)

**Dimensions:** 133mm x 102mm x 51mm (5.25" x 4.00" x 2")

**Shipping Weight:** 1.13 kg (2.5 lbs.)

**Environmental:** -26°C to 54°C (-15°F to 130°F) with 5% to 95% non-condensing humidity

**Material:** .062" (16 gauge) steel, **E-1600A** - Red powder paint, **E-1600-45A** - High visibility yellow powder paint

**Connections:** RJ11

**Mounting:** Surface mount to walls, posts, single gang boxes and 4" x 4" electrical junction boxes or recess mount in elevator phone boxes

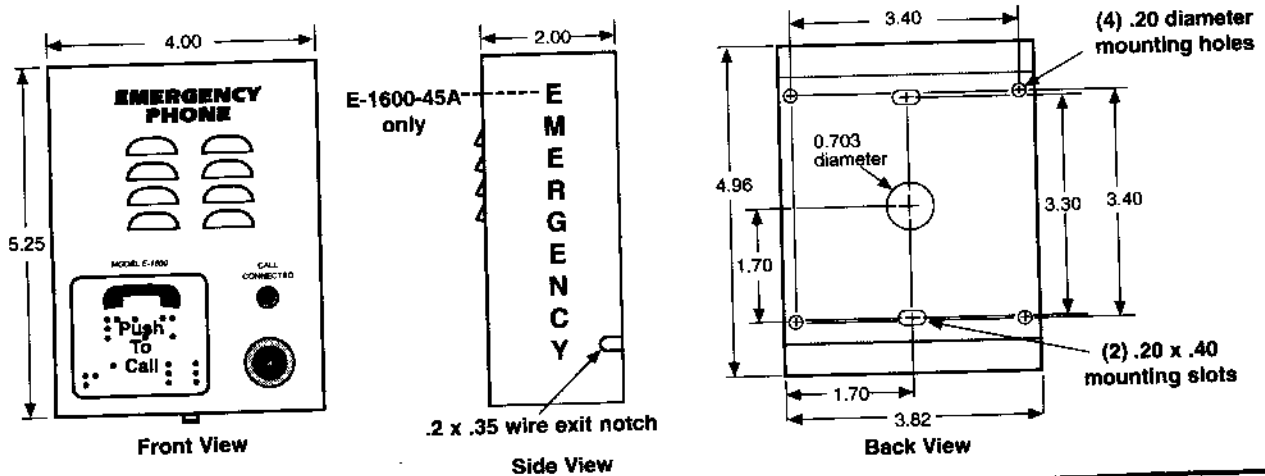

## E-1600-02A

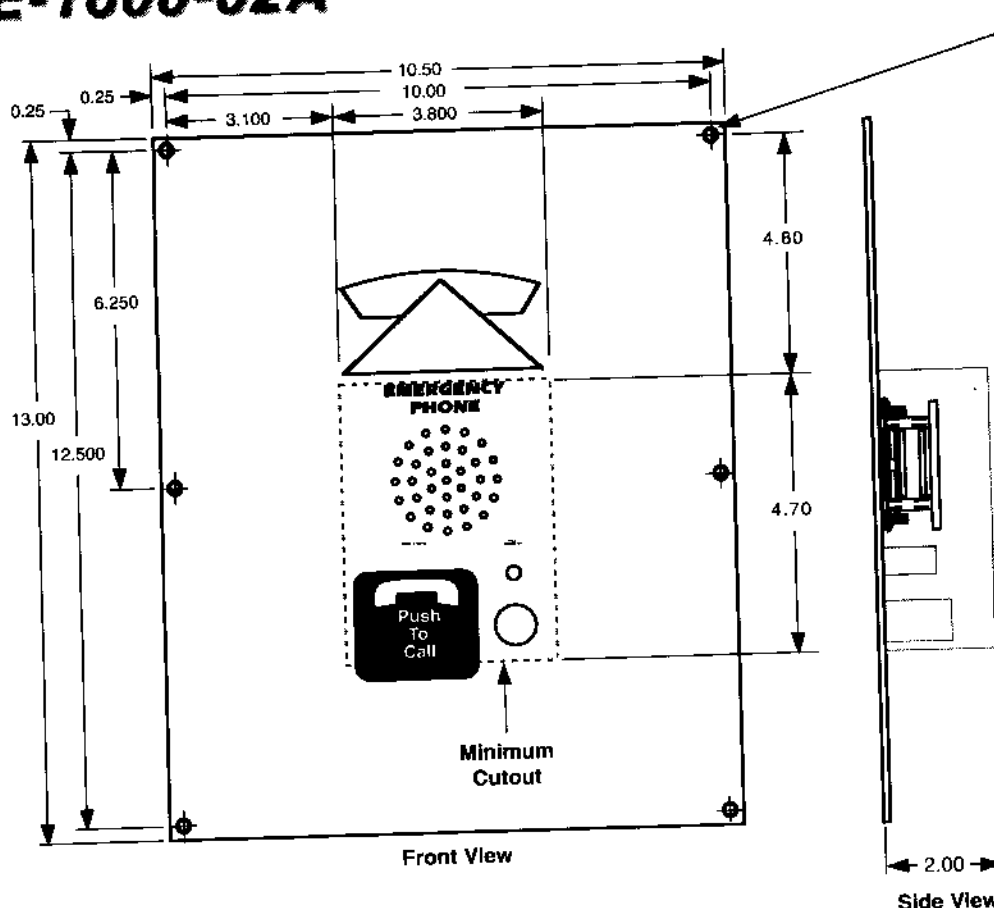

(6) 0.188 diameter countersunk holes

**Suggested Hardware:** (6) #8 x 3/4 flat head phillips sheet metal type A screws (not included)

**Power:** Phone line powered (24VDC talk battery w/20mA loop current minimum)

**Dimensions:** 330mm x 267mm x 51mm (13" x 10.5" x 2")

**Shipping Weight:** 3.18 kg (7 lbs.)

**Environmental:** -26°C to 54°C (-15°F to 130°F) with 5% to 95% non-condensing humidity

**Connections:** RJ11

**Material:** .125" (11 gauge) brushed stainless steel

**Mounting:** Flush mounted in elevator cabs, ATM machines, stairwells, hallways, etc.

# E-1600-03A

**Power:** Phone line powered (24VDC talk battery w/20mA loop current minimum)

**Dimensions:** 183mm x 149mm x 39mm (7.22" x 5.86" x 1.55")

**Shipping Weight:** 1.36 kg (3 lbs.)

**Environmental:** -26°C to 54°C (-15°F to 130°F) with 5% to 95% non-condensing humidity

**Material:** .074" (14 gauge) Brushed stainless steel panel and extra heavy duty button

**Connections:** RJ11

**Mounting:** For use in high vandalism areas. Surface mounted to walls, posts, single gang and 4" x 4" electrical junction boxes or recess mounted in elevator phone box.

**Note:** For greater weather resistance, apply a bead of clear silicon caulking around the top edge and sides of the chassis.

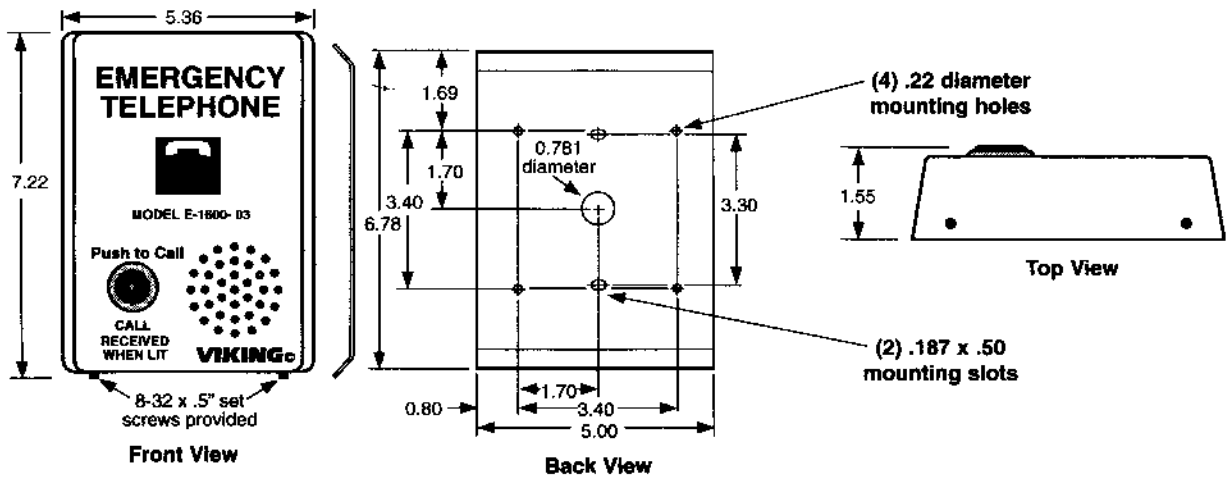

# E-1600-50A

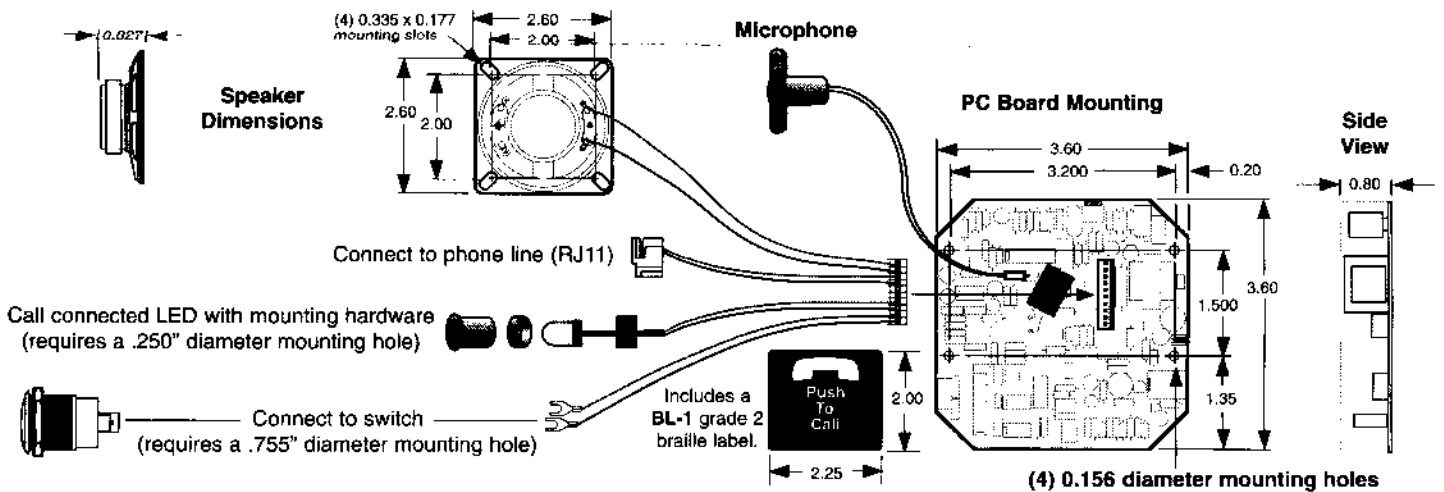

# K-1600-EHFA

**Power:** Phone line powered (24VDC talk battery w/20mA loop current minimum)

**Dimensions:** 251mm x 174mm x 53mm (9.875" x 6.86" x 2.10")

**Shipping Weight:** .91 kg (2 lbs.)

**Environmental:** -26°C to 54°C (-15°F to 130°F) with 5% to 95% non-condensing humidity

**Material:** .062" (16 Gauge) Red powder painted aluminum

**Connections:** RJ11

**Mounting:** Recess mounted in elevator phone box

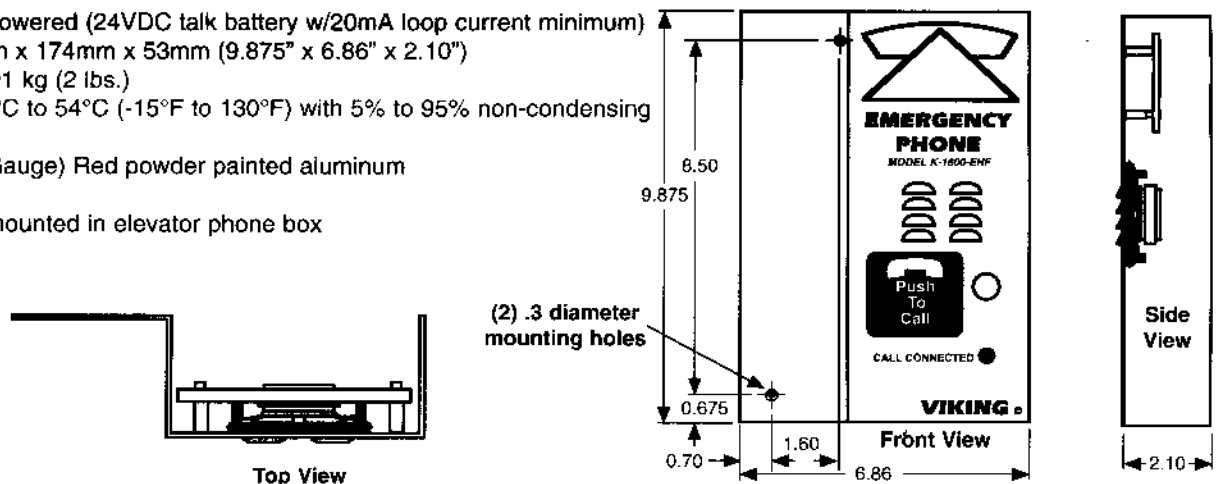

# Programming

## A. Accessing the Programming Mode

The 1600A series emergency phones can be programmed from any Touch Tone phone using a C.O. line or analog PABX/KSU station.

### 1. Using the Security Code

- Move DIP switch 2 to the **ON** position (see section I).
- From a Touch Tone phone, call the line attached to the 1600A series phone.
- When the 1600A series phone answers, enter the 6-digit security code (see section B).

### 2. Without the Security Code

- Move DIP switch 2 to the **ON** position (see section I).
- Move DIP switch 3 to the **OFF** position (see section I).
- From a Touch Tone phone, call the line attached to the 1600A series phone.
- When the 1600A series phone answers, you will be automatically entered into the programming mode.

**Important:** After programming, move DIP switch 3 to the **ON** position.

## B. Security Code (memory location #19)

The security code allows the user/installer to program the 1600A series phone while DIP switch 3 is in the **ON** (normal) position. The factory set security code is 845464 (V-I-K-I-N-G). It is recommended that the factory set security code be changed.

**Example:** To store 123456 as the security code, enter: **1 2 3 4 5 6 # 1 9**

**Note:** The security code must be 6 digits and cannot include a \* or a #.

## C. Up to 5 Speed Dial Numbers (memory location #00 - #04)

The speed dial number programmed in location #00 is the telephone or extension number that is dialed when the "Push To Call" button is first pressed. Additional speed dial numbers will be dialed when there is no answer or a busy signal is detected and the next number redial features are activated. The 1600A series phone will cycle through the programmed speed dial numbers until answered. To program, enter the desired speed dial number followed by the location number (#00 - #04).

**Example:** To store 555-1234 as the primary speed dial number, enter: **5 5 5 1 2 3 4 # 0 0**

**Example:** To store a Touch Tone 9, a four second pause and then a pulse dialed 333-4444 into the secondary speed dial memory position enter: **9 \*7 \*6 3 3 3 4 4 4 4 # 0 1**

To clear a speed dial location, simply enter the location (#00 - #04) without any previous numbers. The 1600A series phone is factory set for all speed dial numbers to be clear.

**Note:** Up to 20 digits can be stored in each of the 5 speed dial positions. Special features such as pause, mode change, Touch Tone \* and # count as single digits.

To Program:	Enter:
0, 1, 2...9	0, 1, 2...9
*	**
#	**#
4 second pause	*7
switch to pulse mode	*6

## D. Identification Number (memory location #20)

The I.D. number (up to 20 digits) is used by emergency personnel to identify the location of the caller and is given out when the receiving party presses a Touch Tone \*. The security office can display the number using the DM-4 Digit Monitor (Fax Back Document 205). To program the I.D. number, enter the desired number followed by #20.

**Example:** To store 333 as the I.D. number, enter: **3 3 3 # 2 0**

## E. Central Station Monitoring

**Important:** You must use the "Central Station Monitoring" Application Note (Fax Back Document 846) in combination with this document to perform any "Central Station" programming. Contact Viking Technical Support at (715) 386-8666.

The 1600A series phone is compatible with receivers using these specific formats: "Contact ID", "Ademco High Speed", "DTMF 4+1 Express" and "DTMF 4+2 Express." The receiving equipment should have the capability of allowing voice communication after the data has been received. If the receiving equipment doesn't have "talk over" features, the 1600A series phone may be programmed to call a voice line after receiving a "kiss off" from the central station.

## F. Timing/Dialing Options (memory location #18)

There are six positions in the timing/dialing options. To program these options, enter the six desired timing/dialing numbers followed by #18. The six available timing/dialing options are defined on the following page.

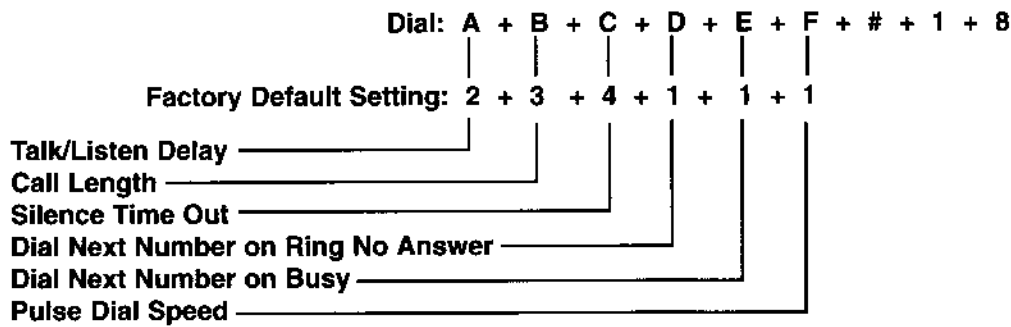

**Setting A - Talk/Listen Delay**

This feature selects switching time between talk and listen modes (VOX switching time). Programmable in increments of .1 seconds up to a maximum of .9 seconds (Touch Tones 1 - 9). **Note:** The factory default is .2 seconds.

**Setting B - Call Length Time Out**

This feature selects the maximum length of time that calls can be connected. Programmable in increments of 1 minute up to a maximum of 9 minutes (Touch Tones 1 - 9). Program 0 in this location to disable the call length time out, then the 1600A series phone must rely on a CPC signal to hang-up. **Note:** The factory default is 3 minutes.

**Setting C - Silence Time Out**

This feature selects the length of time that calls will remain connected without voice activity. Programmable in increments of 10 seconds up to a maximum of 90 seconds (Touch Tones 1 - 9). To disable the silence time out, program 0 in this location. **Note:** The factory default is 40 seconds.

**Setting D - Dial the Next Number on Ring No Answer**

If enabled and a ring-no-answer is detected, the 1600A series phone will dial the next programmed speed dial number, and continue to cycle through the emergency numbers until a call is completed. **Note:** This feature is disabled in the factory default setting.

Digits	Setting D
1 or 0	Disabled
2, 3, 4...9	Dials second number after 2, 3, 4...9 rings respectively

**Setting E - Dial the Next Number on Busy**

If enabled and a busy is detected, the 1600A series phone will dial the next programmed speed dial number, and continue to cycle through the emergency numbers until a call is completed. **Notes:** This feature is disabled in the factory default setting. If the busy signal is interrupted with a promotional message, contact your central office to have it removed.

Digits	Setting E
1	Disabled
2	Enabled

**Setting F - Pulse Dialing Rate (Pulses per second)**

The 1600A series phone is capable of dialing different pulse speeds. **Note:** The factory default setting is 10pps.

Digits	Setting F
1	10 pps
2	20 pps

**G. Voice Announcer Options (memory location #17)**

The 1600A series phones have a built-in non-volatile digital voice announcer that may be used to identify the location of the emergency phone call. The 10 seconds of digital record time is recorded remotely from a Touch Tone phone. Programming options are as follows:



**Settings A and B - Forced Play Time**

The 1600A series phone is factory set to automatically start playing the voice announcement after it has determined the call has been answered. Alternately, the announcement may be programmed to play after a programmed amount of time, from 1 (enter "01") to 99 seconds after dialing. If the forced play time is used, it is important to allow enough time for the 1600A series phone to detect ring-no-answer and busy signals when using the redial features. To set it to play automatically, enter "00" in the forced play time location. **Note:** The factory default is 00, play automatically.

### Setting C - Repeat Announcement Option

The 1600A can be programmed to play the announcement from 1-9 times (enter digits 1-9), or to continuously repeat the announcement every 8 seconds (enter digit 0) until a Touch Tone \* is detected from the distant party.

The I.D. number (if programmed) will be sent and the call connected LED will turn on automatically after the announcement has stopped repeating. Note: The factory default for the 1600A series phone is to repeat until a \* is detected (digit 0).

### H. Recording the Announcement

1. Call into the 1600A series phone with a Touch Tone phone and access programming.
2. Enter \*4, wait for the tone and then begin recording. Ten seconds of record time is available.
3. Enter any Touch Tone to stop the recording. Playback is automatic.
4. Enter \*5 to review the announcement again.
5. If you choose to not use a voice announcement, enter \*3 to clear the recording.

**Example:** "Elevator number 1215, located in the Trade Center Building, needs assistance. Press the asterisk (\*) key on your telephone to start and stop this announcement..."

### I. DIP Switch Programming/Microphone Adjustment

A POT is provided to increase or decrease microphone sensitivity. In certain noisy locations the microphone sensitivity may need to be decreased as shown below. **Caution:** Setting the microphone gain too high may cause distorted audio, prevent the distant party from breaking over and inhibit second number redialing.

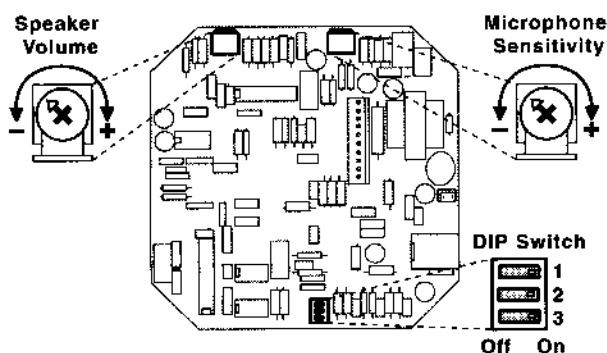

#### DIP Switch 1 - Front Panel Push Button Switch

- ON - Button alternately connects and disconnects calls
- OFF - Button connects calls only

#### DIP Switch 2 - Incoming Call Select

- ON - Incoming calls are answered
- OFF - Incoming calls are not answered

#### DIP Switch 3 - Operating Mode

- ON - Normal operation mode
- OFF - Learn mode

Any incoming calls are automatically entered into the programming mode (no security code required). Use this option if you have forgotten your security code.

## Operation

When the Push to Call button is pressed, the 1600A series phone goes off-hook and dials a pre-programmed telephone number. The Call Connected LED momentarily flashes during tone or pulse dialing. In the event that the line is busy or there is a ring-no-answer, the unit can be programmed to call additional phone numbers. The emergency phone then cycles through up to 5 pre-programmed numbers until the call is answered. When the call is answered, handsfree communication to emergency personnel is established. The digital voice announcer will automatically play to identify the location of the emergency call. The \* key will stop the announcement, send the I.D. number (if programmed) and light the "Call Connected" LED. Alternatively, the 1600A series phone can be programmed to automatically light the "Call Connected" LED after the announcement has played a programmed number of times. The distant party will know the location of the emergency call by either the voice announcement or by decoding the I.D. number using Viking's DM-4 Digit Monitor. Pressing the \* key again will send the I.D. number and play the message again. Once the \* key has been pressed, the # key can be used to force the 1600A series phone to hang-up.

## Options

The optional PB-100 system is available to provide centralized polling and diagnostics of the 1600 and 1600A series emergency phones. This system is ideal for periodically testing each emergency phone and phone line for functionality. For more information, retrieve Fax Back Document 232.

The E-1600A, K-1600-EHFA and E-1600-02A phones can be supplied with special graphics. In addition to special graphics, the E-1600A can be supplied blank and/or with special colors. Please contact Viking for minimum quantities, set up charges and unit costs. Typical delivery is 4 to 6 weeks.

**Product Support Line...715.386.8666**

**Fax Back Line...715.386.4345**

Due to the dynamic nature of the product design, the information contained in this document is subject to change without notice. Viking Electronics, and its affiliates and/or subsidiaries assume no responsibility for errors and omissions contained in this information. Revisions of this document or new editions of it may be issued to incorporate such changes.